

Name: 5ml Bottle
Material: PET
Weight: 3.2g
Mode: Injection blow molding
Machine: Novapax NSB405
Stations: 4
Cavities: 16
Cycle time: 9s
Pieces per hour: 6400
max. cavities on machine: 16

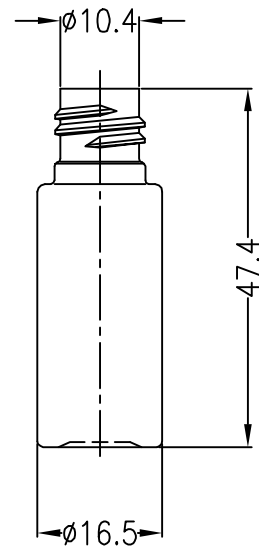

Name: 35ml Bottle
Material: PET
Weight: 5.2g
Mode: Injection blow molding
Machine: Novapax NSB320
Stations: 4
Cavities: 4
Cycle time: 13
Pieces per hour: 1100
max. cavities on machine: 6 (1650 pph)

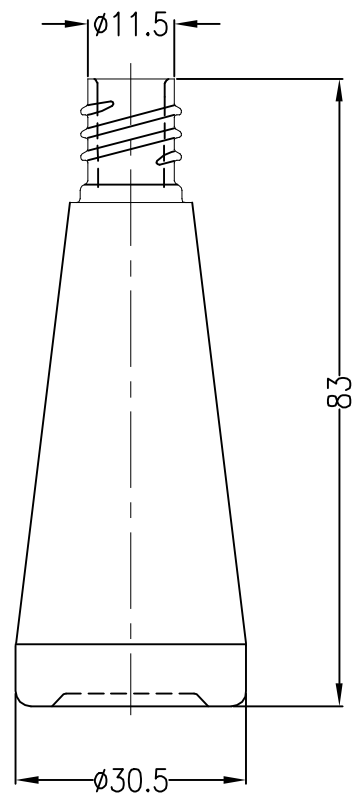

Name: 38ml Bottle
Material: PET
Weight: 10.5g
Mode: Injection blow molding
Machine: Novapax NSB650
Stations: 4
Cavities: 10
Cycle time: 13
Pieces per hour: 2270
max. cavities on machine: 10

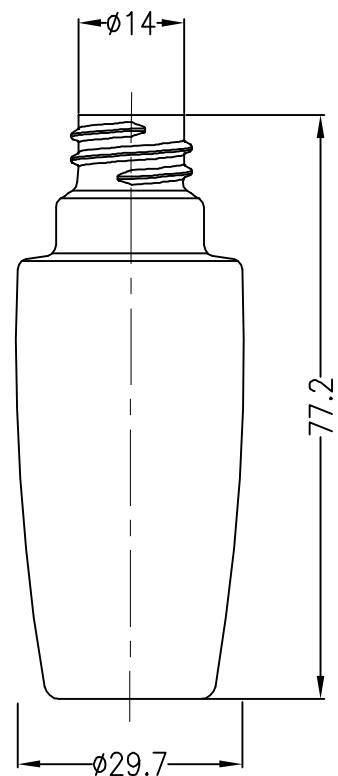

Name: Twin Bottle
Material: PET
Weight: 10g
Mode: Injection blow molding
Machine: Novapax NSB400
Stations: 4
Cavities: 6
Cycle time: 15
Pieces per hour: 1140
max. cavities on machine: 8 (1920 pph)

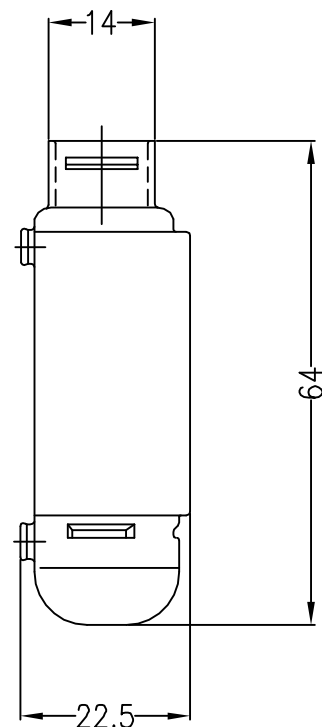

Name: 300ml Jar
Material: PET
Weight: 35g
Mode: Injection blow molding
Machine: Suma 40IB
Stations: 3 (cores with cooling)
Cavities: 2
Cycle time: 16s
Pieces per hour: 450
max. cavities on machine: 4 (900 pph)

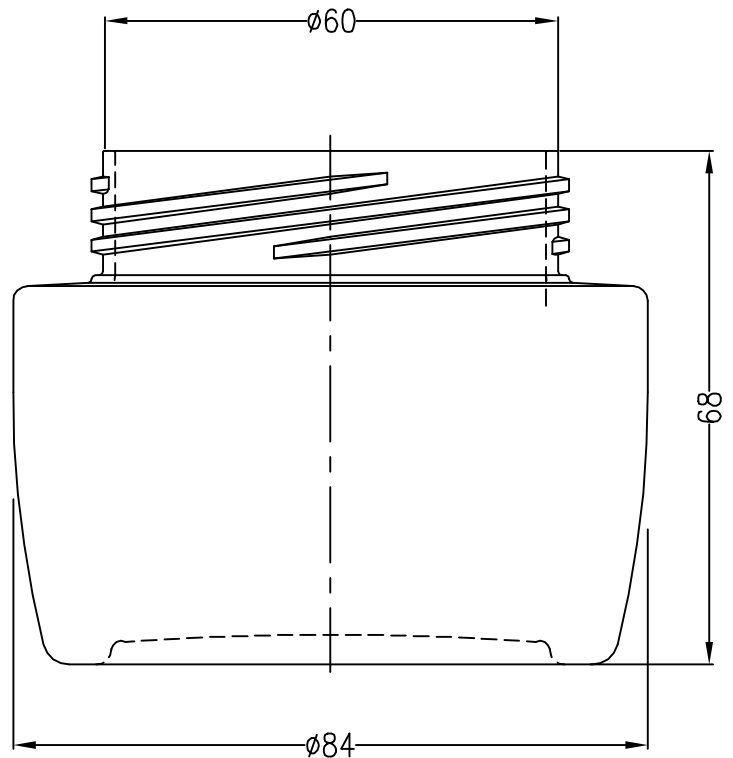

Name: 210ml Jar
Material: PET
Weight: 22g
Mode: Injection blow molding
Machine: Novapax NSB320
Stations: 4
Cavities: 2
Cycle time: 14
Pieces per hour: 515
max. cavities on machine: 4 (1030 pph)

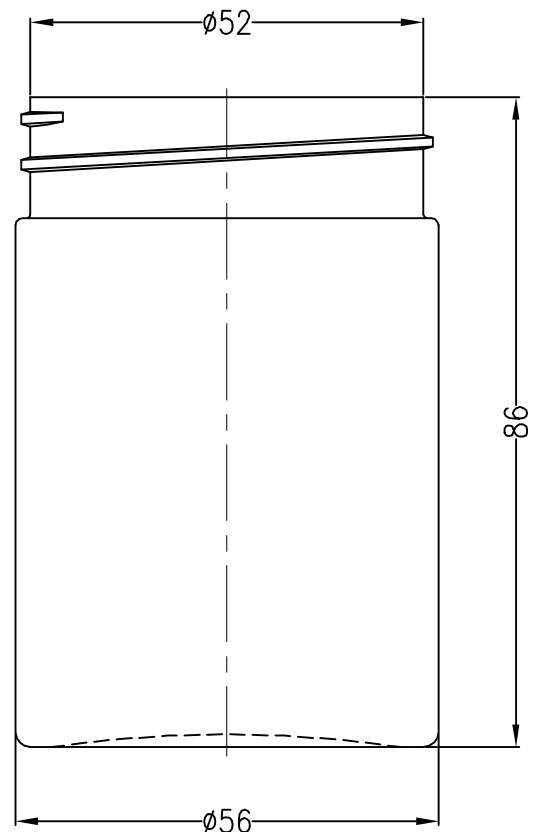

Name:	85ml Jar
Material:	HDPE
Weight:	12g
Mode:	Injection blow molding
Machine:	Uniloy IB85
Stations:	3
Cavities:	6
Cycle time:	13
Pieces per hour:	<u>1660</u>
max. cavities on machine:	6

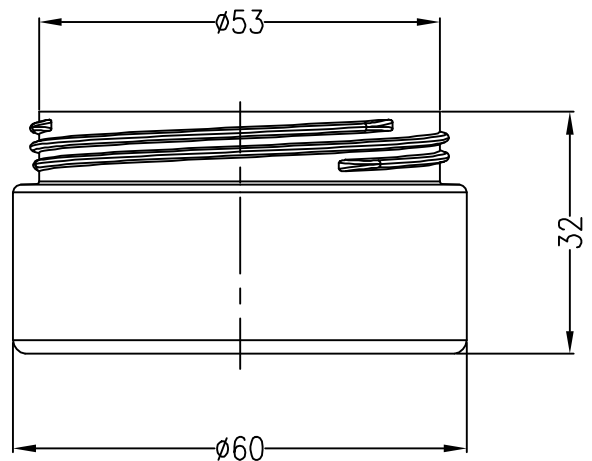

Name: 40ml oval bottle
Material: LDPE
Weight: 10g
Mode: Injection blow molding
Machine: Novapax NSB 320
Stations: 4
Cavities: 4
Cycle time: 15
Pieces per hour: 960
max. cavities on machine: 4

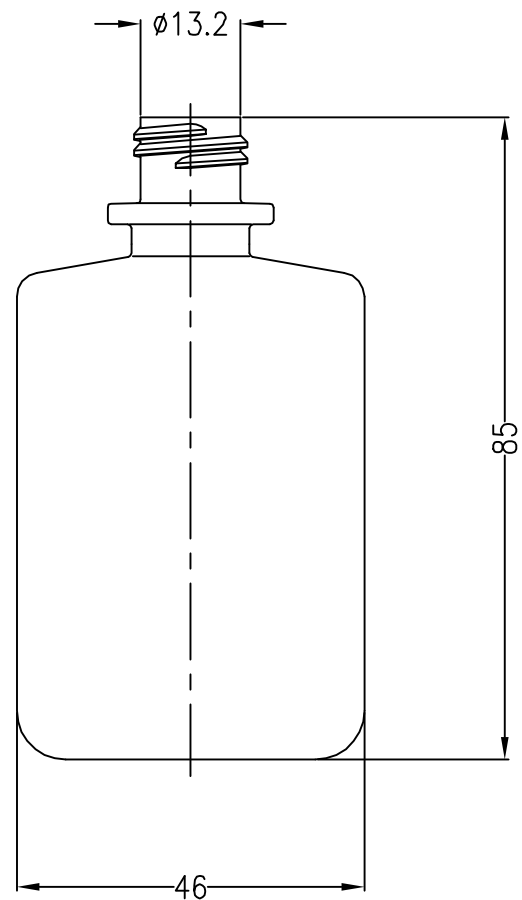

Name: 220ml bottle
Material: HDPE
Weight: 28g
Mode: Injection blow molding
Machine: Novapax NSB 400
Stations: 4
Cavities: 4
Cycle time: 15
Pieces per hour: 960
max. cavities on machine: 4

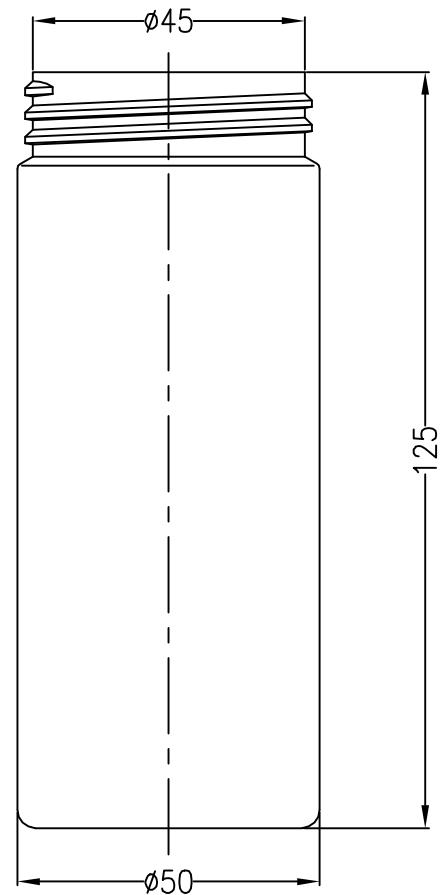

Name: 70ml bottle
Material: HDPE
Weight: 5.2g
Mode: Injection blow molding
Machine: Novapax NSB 320
Stations: 4
Cavities: 6
Cycle time: 8
Pieces per hour: 2700
max. cavities on machine: 6

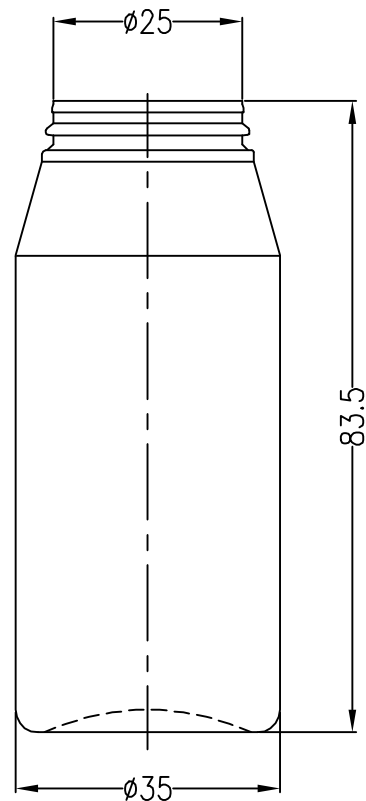

Name: 5.5ml Bottle
Material: PP
Weight: 1.9g
Mode: Injection blow molding
Machine: Novapax NSB400
Stations: 4
Cavities: 8
Cycle time: 10
Pieces per hour: 2880
max. cavities on machine: 12 (4320 pph)

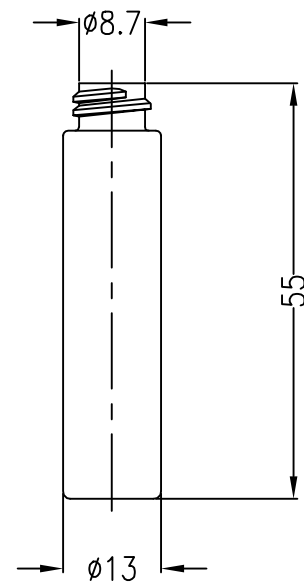

Name: 15.5ml Bottle
Material: PP
Weight: 5.2g
Mode: Injection blow molding
Machine: Novapax NSB320
Stations: 4
Cavities: 6
Cycle time: 13
Pieces per hour: 1660
max. cavities on machine: 6

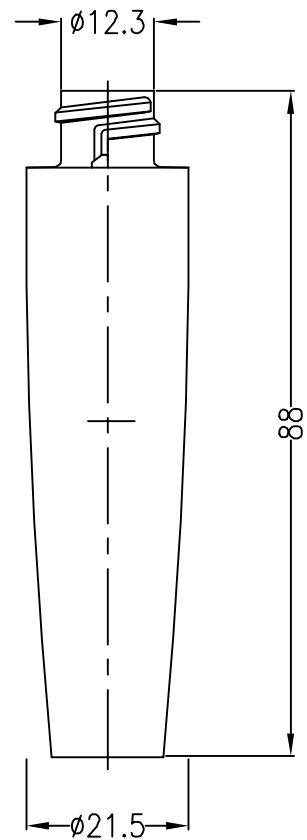

Name: Slim Bottle
Material: PCTA
Weight: 8.5
Mode: Injection blow molding
Machine: Novapax NSB400
Stations: 4
Cavities: 8
Cycle time: 15
Pieces per hour: 1920
max. cavities on machine: 12 (2880 pph)

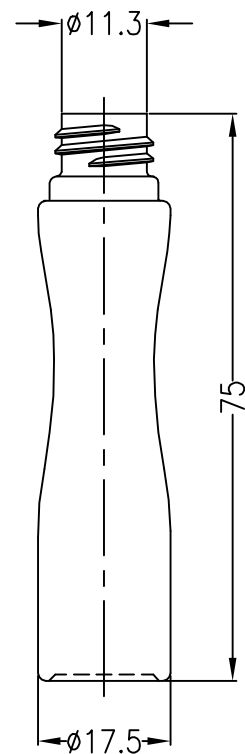

Name: 12ml Bottle
Material: PA
Weight: 8g
Mode: Injection blow molding
Machine: Novapax NSB 650
Stations: 4
Cavities: 8
Cycle time: 14
Pieces per hour: 2050
max. cavities on machine: 12 (3075 pph)

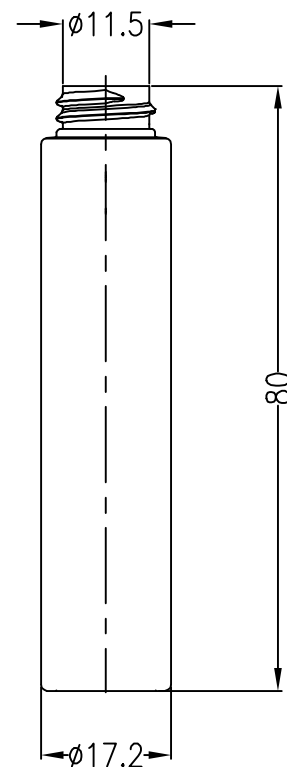

Tospag GmbH

www.tospag.ch
info@tospag.ch

+41 44 814 37 92
Switzerland

Name: 60ml Bottle
Material: Surlyn
Weight: 9.2g
Mode: Injection blow molding
Machine: Novapax NSB405
Stations: 4
Cavities: 4
Cycle time: 12
Pieces per hour: 1200
max. cavities on machine: 8 (2400 pph)

